

1.	Content	
2-3	Cover	
4.	SOFB	Olympic Flat Bench
5.	SOIB	Olympic Incline Bench
6.	SODB	Olympic Decline Bench
7.	SOMB	Olympic Military Bench
8.	SOBWS	Olympic Bench Weight Storage
9.	SOSR	Olympic Squat Rack
10.	SOWT	Olympic Weight Tree
11.	SSM	Smith Machine
12.	SMAB	Multi Adj. Bench
13.	SLR	Leg Raise
14.	SBE	Back Extension
15.	SCDLR	Chin / Dip / Leg Raise
16.	SABC	AB Crunch Bench
17.	SADB	Adj.-AB Decline Bench
18.	SAC	Arm Curl Bench
19.	SUB	Utility Bench
20.	SFB	Flat Bench
21.	SDR1	Single Tier Dumbbell Rack
22.	SDR2	Double Tier Dumbbell Rack
23.	SBBR	Barbell Rack
24.	SHR	Handle Rack

COLOR CHART

Frame Colors



Upholstery Colors



Custom Colors

In addition to standard colors, we offer custom colors. Contact your sales representative for more information.

*Only available for workbenches on Signature Plate-Loaded

All products are not available in all colors. See charts below for full color specifications.

STRENGTH FRAME COLOR CHART

Key * Standard ◊ Optional - Unavailable † Custom †† Premium

Color	Signature Series									Hammer Strength		
	Single Stations and Cable Motion	Benches and Racks	Plate-Loaded*	Synergy960	Pro2 SE Series	Pro2 Series	Circuit Series	Optima Series	Fit Series	MTS	Plate-Loaded and Benches and Racks	HD Elite
Platinum	+	+	+	+	+	+	+	+	+	+	+	+
White	+	+	+	+	+	+	+	◊	-	+	+	+
Black	+	-	+	+	+	◊	+	◊	-	+	+	+
Ice Blue Metallic	+	-	+	+	+	◊	+	◊	-	+	+	+
Midnight Metallic	+	-	+	+	+	◊	+	◊	-	+	+	+
Nickel	+	-	+	+	+	◊	+	◊	-	+	+	+
Blue	+	-	+	+	+	◊	+	◊	-	+	+	+
Red	+	-	+	+	+	◊	+	◊	-	+	+	+
Yellow	+	-	+	+	+	◊	+	◊	-	+	+	+
Shadow Gray*	-	-	-	-	-	-	-	-	-	-	-	-
Candy Apple Red	††	-	††	††	††	-	††	††	-	††	-	-
Custom	†	-	†	†	†	-	-	-	-	†	†	†

*Signature Series Plate-Loaded Shade in Gray only available for workbenches

STRENGTH UPHOLSTERY COLOR CHART

Color	Signature Series									Hammer Strength		
	Single Stations and Cable Motion	Benches and Racks	Plate-Loaded	Synergy960*	Pro2 SE Series	Pro2 Series	Circuit Series	Optima Series	Fit Series	MTS	Plate-Loaded and Benches and Racks	HD Elite
Black	+	+	+	+	+	+	+	+	+	+	+	+
A.m. Beauty Red	+	+	+	+	+	◊	+	◊	-	+	+	+
Azure	+	+	+	+	+	◊	+	◊	-	+	+	+
Burgundy	+	+	+	+	+	◊	+	◊	-	+	+	+
Cranberry	+	+	+	+	+	◊	+	◊	-	+	+	+
Candy Apple Red	+	+	+	+	+	◊	+	◊	-	+	+	+
Chestnut	+	+	+	+	+	◊	+	◊	-	+	+	+
Concord	+	+	+	+	+	◊	+	◊	-	+	+	+
Crocus	+	+	+	+	+	◊	+	◊	-	+	+	+
Graphite	+	+	+	+	+	◊	+	◊	-	+	+	+
Dove Gray	+	+	+	+	+	◊	+	◊	-	+	+	+
Emerald	+	+	+	+	+	◊	+	◊	-	+	+	+
Grotto	+	+	+	+	+	◊	+	◊	-	+	+	+
Gun Metal	+	+	+	+	+	◊	+	◊	-	+	+	+
Hunter Green	+	+	+	+	+	◊	+	◊	-	+	+	+
Imperial Blue	+	+	+	+	+	◊	+	◊	-	+	+	+
Jade	+	+	+	+	+	◊	+	◊	-	+	+	+
Navy	+	+	+	+	+	◊	+	◊	-	+	+	+
Northwoods Green	+	+	+	+	+	◊	+	◊	-	+	+	+
Paprika	+	+	+	+	+	◊	+	◊	-	+	+	+
Plum	+	+	+	+	+	◊	+	◊	-	+	+	+
Royal Blue	+	+	+	+	+	◊	+	◊	-	+	+	+
Putty	+	+	+	+	+	◊	+	◊	-	+	+	+
Regimental Blue	+	+	+	+	+	◊	+	◊	-	+	+	+
Slate	+	+	+	+	+	◊	+	◊	-	+	+	+
Space Blue	+	+	+	+	+	◊	+	◊	-	+	+	+
Suede	+	+	+	+	+	◊	+	◊	-	+	+	+
Terra Cotta	+	+	+	+	+	◊	+	◊	-	+	+	+
Turquoise	+	+	+	+	+	◊	+	◊	-	+	+	+
Wheat	+	+	+	+	+	◊	+	◊	-	+	+	+
Custom	†	†	†	†	†	†	†	-	-	†	†	†

*Synergy960 upholstery only available for Robosunder

Revisions and Custom frame and upholstery are available for an additional charge.

Signature Series Benches and Racks



Strength in Beauty

Aesthetics. Performance. Integration. Introducing Signature Series Benches and Racks from Life Fitness—uniquely designed to deliver the performance features that experienced users demand, while offering the approachability new users desire. Only our new line of benches and racks delivers a design that seamlessly integrates with our Signature and Cable Motion series, creating a family of 44 superior strength-training products. The new Life Fitness Signature Series Benches and Racks combine the best in performance, function, and aesthetics to attract new users and keep them coming back for more.

Signature Series Benches and Racks Features:

- An appealing design featuring large, flat oval tubing and contour cushions creating an approachable yet robust appearance.
- Places the user in the optimal workout position to maximize results.
- Molded urethane protective racking systems and molded paint guards to protect against chipping and scratching combine to create the durability you expect from Life Fitness.
- An integrated, modular labeling system for plat and dumbbell storage—consistent with labeling on other Life Fitness strength products—keeps free weights, and your facility, organized.

Free Weight Equipment

Project :

Item No. :

Signature Olympic Flat Bench

Key Features:

- Molded Urethane Protective Racking System protects bar from wear and helps reduce noise



Machine Weight	150 lbs (68 kg)
Dimensions (L x W x H)	51" x 49" x 51" (130 x 124.5 x 130) cm
Origin	Hungary
Product Code	SOFB

Free Weight Equipment

Project :

Item No. :



Signature Olympic Incline Bench

Key Features:

- 30-degree back pad angle
- Molded Urethane Protective Racking System protects bar from wear and helps reduce noise



Machine Weight	185 lbs (84 kg)
Dimensions (L x W x H)	51" x 58" x 57" (130 x 147 x 144) cm
Origin	Hungary
Product Code	SOIB

Free Weight Equipment

Project :

Item No. :

Signature Olympic Decline Bench

Key Features:

- -15-degree back pad angle
- Adjustable kneepad accommodates users of all sizes
- Molded Urethane Protective Racking System protects bar from wear and helps reduce noise



Machine Weight	210 lbs (95 kg)
Dimensions (L x W x H)	
	51" x 68" x 51" (130 x 173 x 130) cm
Origin	
	Hungary
Product Code	
	SODB

Free Weight Equipment

Project :

Item No. :

Signature Olympic Military Bench

Key Features:

- Forward and rear racking system offers lifting variety
- Molded Urethane Protective Racking System protects bar from wear and helps reduce noise
- Molded urethane guards protect frame from paint chips and scratches



Machine Weight	325 lbs (148 kg)
Dimensions (L x W x H)	51" x 48" x 66" (129.5 x 122 x 168)
Origin	Hungary
Product Code	SOMB

Free Weight Equipment

Project :

Item No. :



Signature Olympic Bench Weight Storage

Key Features:

- Eight weight horns: four large external horns and four small internal horns
- Integrated weight horn labels identify plate storage positions
- Note: Shown here with optional Olympic Flat Bench (SOFB). Also can be attached to SOIB, SODB and SOMB



Machine Weight	85 lbs (39 kg)
Dimensions (L x W x H)	17" x 28" x 49" (43 x 71 x 124.5) cm
Origin	Hungary
Product Code	SOBWS

Free Weight Equipment

Project :

Item No. :

Signature Olympic Squat Rack

Key Features:

- Five racking positions and eight weight horns
- Molded Urethane Protective Racking System protects bar from wear and helps reduce noise
- Molded urethane guards protect frame from paint chips and scratches



Machine Weight	400 lbs (182 kg)
Dimensions (L x W x H)	66" x 77.5" x 75.5" (168 x 197 x 192) cm
Origin	Hungary
Product Code	SOSR

Benches & Racks

Project :

Item No. :



Signature Olympic Weight Tree

Key Features:

- 6 weight horns will accommodate up to 20 – 45 lb. weight plates
- Weight horn labels for assigned weight placement



Machine Weight	95lbs (43 kg)
Dimensions (L x W x H)	
	23" x 27" x 37" (59 x 69 x 94) cm
Origin	
	Hungary
Product Code	
	SOWT

Free Weight Equipment

Project :

Item No. :



Signature Smith Machine

Key Features:

- 7-degree bar angle follows the natural free weight path of movement for pressing or squatting
- Fully enclosed linear bearings with unsupported guide rods
- Counter weight inside the D-tube eliminates shrouds
- Shown with optional Signature Series Multi-Adjustable Bench

* Ceiling High Requirement 2.5m

*Bench & Weight Plates not included

Machine Weight	580 lbs (263 kg)
Dimensions (L x W x H)	
49" x 87" x 93" (124 x 221 x 237) cm	
Origin	Hungary
Product Code	SSM

Free Weight Equipment

Project :

Item No. :

Signature Multi Adj. Bench

Key Features:

- Adjustment angles: 0°, 20°, 30°, 40°, 50°, 60°, 70°
- Patent pending single adjustment mechanism optimally position the seat and back pad at all adjustment angles
- Drop-down handle and wheels for easy transport



Machine Weight	125 lbs (57 kg)
Dimensions (L x W x H)	
53" x 32" x 17.5" (135 x 81 x 44.5) cm	
Origin	Hungary
Product Code	SMAB

Core Training Equipment

Project :

Item No. :

Signature Leg Raise

Key Features:

- Unique back pad support provides optimal stabilization throughout range of motion
- Handles and foot platforms ensure easy start position for users of all sizes



Machine Weight	140 lbs (63.5 kg)
Dimensions (L x W x H)	
46" x 33" x 64" (117 x 83 X 161) cm	
Origin	Hungary
Product Code	SLR

Core Training Equipment

Project :

Item No. :

Signature Back Extension

Key Features:

- Angled pad for comfort and support
- Lower roller support provides stabilization and comfort throughout exercise

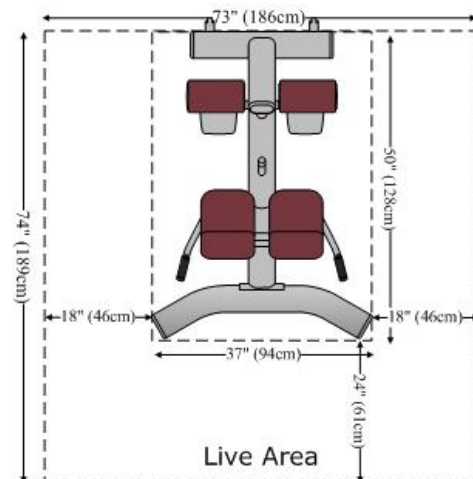

Machine Weight	151 lbs (68 kg)
Dimensions (L x W x H)	50" x 37" x 38" (127 x 94 x 97 cm)
Origin	Hungary
Product Code	SBE

Core Training Equipment

Project : Mandarin Oriental Hong Kong



Signature Chin / Dip / Leg Raise

Key Features:

- Three body weight exercises in one, space-efficient unit
- Multiple pull-up grip angles offer variety and comfort
- Contoured elbow pads and oversized dip handles provide added comfort
- Molded urethane guards protect frame



* Ceiling High Requirement 2.6m

Machine Weight	245lbs (111 kg)
Dimensions (L x W x H)	45" x 50" x 91.5" (114 x 127 x 233) cm
Origin	Hungary
Product Code	SCDLR

Core Training Equipment

Project :

Item No. :



Signature Ab Crunch Bench

Key Features:

- The contemporary design with oval tubing and contoured upholstery compliments our Cable Motion and Signature Series lines
- The biomechanics of our smooth AbCam™ System offer a remarkably natural exercise that is ergonomically designed to maximize ab contraction and minimize hip flexion
- Integrated weight horn allows users to add resistance for a more challenging workout
- No time-consuming adjustments are required for each new user. The ergonomically-angled pads and foot pegs provide superior comfort and stabilization regardless of exerciser's size
- Easy-to follow instructional placard illustrates proper use

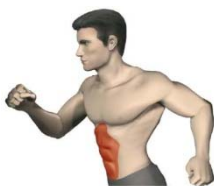

Start



Finish



Machine Weight	141 lbs (64 kg)
Dimensions (L x W x H)	62" x 32" x 38" (158 x 81 x 97) cm
Origin	Hungary
Product Code	SABC

Core Training Equipment

Project :

Item No. :

Signature Adj.-Ab. Decline Bench

Key Features:

- Adjustment angles: -10.5°, -15.5°, -20.5°, -25.5°
- Drop-down handle and wheels for easy mobility



Machine Weight	135lbs (61 kg)
Dimensions (L x W x H)	
64" x 44" x 32" (163 x 112 x 81) cm	
Origin	Hungary
Product Code	SADB

Free Weight Equipment

Project :

Item No. :

Signature Arm Curl Bench

Key Features:

- Two arm curl exercises in one machine: standing 45-degree preacher curl and standing 85-degree biceps curl
- Accommodates users of all sizes with no adjustments
- Molded urethane guards protect frame from paint chips and scratches



*Olympic Bar & Weight Plates not included

Machine Weight	210 lbs (95 kg)
Dimensions (L x W x H)	33" x 47" x 46" (84 x 119 x 117) cm
Origin	Hungary
Product Code	SAC

Free Weight Equipment

Project :

Item No. :

Signature Utility Bench

Key Features:

- Seat is positioned low to the ground for maximum comfort and stability
- 80° back pad angle



Machine Weight	50 lbs (23 kg)
Dimensions (L x W x H)	28" x 36" x 36" (71 x 90 x 90) cm
Origin	Hungary
Product Code	SUB

Free Weight Equipment

Project :

Item No. :

Signature Flat Bench

Key Features:

- Vertical front leg reduces trip hazards
- 16 ½" bench height is optimal for dumbbell training



Machine Weight	65 lbs (30 kg)
Dimensions (L x W x H)	46" x 31" x 16.5" (117 x 80 x 42) cm
Origin	Hungary
Product Code	SFB

Free Weight Equipment

Project :

Item No. :

Signature Single Tier Dumbbell Rack



Key Features:

- 10 dumbbell saddles accommodating 50 pairs of dumbbells
- Dumbbell rack labels between saddles to ensure proper placement of dumbbells



Machine Weight	190 lbs (86 kg)
Dimensions (L x W x H)	
90" x 22" x 29" (229 x 56 x 74) cm	
Origin	
Hungary	
Product Code	
SDR1	

Bench & Racks

Project :

Item No. :

Signature Double Tier Dumbbell Rack

Key Features:

- Accommodates ten pairs of dumbbells
- Integrated labeling system for dumbbell placement



Machine Weight	275 lbs (125 kg)
Dimensions (L x W x H)	90" x 25" x 33" (229 x 64 x 84) cm
Origin	Hungary
Product Code	SDR2

Free Weight Equipment

Project :

Item No. :



Signature Barbell Rack

Key Features:

- Accommodates 10 barbells
- Molded urethane paint guards protect the frame for paint chips and scratches

Machine Weight	170lbs (77 kg)
Dimensions (L x W x H)	38" x 33" x 60" (97 x 84 x 152) cm
Origin	Hungary
Product Code	SBBR

Free Weight Equipment

Project :

Item No. :

Signature Handle Rack

Key Features:

- Six hooks store hanging accessories
- Three bar supports provide small barbell storage
- Accessory tray offers storage for other items
- Molded urethane guards protect frame from paint chips and scratches



Machine Weight	140 lbs (64 kg)
Dimensions (L x W x H)	30" x 30" x 38" (76 x 76 x 97) cm
Origin	Hungary
Product Code	SHR

1.	Content	
2-6.	Cover	
7.	CMCP	Chest Press
8.	CMSP	Shoulder Press
9.	CMRW	Row
10.	CMPD	Pulldown
11.	CMDAP	Dual Adjustable Pulley
12.	CMDAP w/ DAP Console	
13.	DAP Console Dual Adjustable Pulley	
14.	CMDAP Photo	
15.	CMDAP	Sample Exercise Options
16.	CMCC	Cable Column
17.	CMACO	Adjustable Cable Crossover
18.	MJ4	4 Stack
19.	MJ5	5 Stack
20.	MJ8	8 Stack
21.	MJ12S	12 Stack Straight
22.	MJ12V	12 Stack V-Shape
23.	MJHAR	Handle / Accessory Rack
24.	HSTV	Hammer Strength Training Vest

COLOR CHART

Frame Colors



Upholstery Colors



Custom Colors

In addition to standard colors, we offer custom colors. Contact your sales representative for more information.

All products are not available in all colors. See charts below for full color specifications.

*Only available for workhorse or Signature Plate-Loaded

STRENGTH FRAME COLOR CHART

Key * Standard ◊ Optional - Unavailable † Custom †† Premium

Color	Signature Series									Hammer Strength		
	Single Stations and Cable Motion	Benches and Racks	Plate-Loaded*	Synergy980	Pro2 SE Series	Pro2 Series	Circuit Series	Optima Series	Fit Series	MTS	Plate-Loaded and Benches and Racks	HD Elite
Platinum	*	*	*	*	*	*	*	*	*	*	*	*
White	*	*	*	*	*	*	*	◊	-	*	*	*
Black	*	-	*	*	*	◊	*	◊	-	*	*	*
Ice Blue Metallic	*	-	*	*	*	◊	*	◊	-	*	*	*
Midnight Metallic	*	-	*	*	*	◊	*	◊	-	*	*	*
Nickel	*	-	*	*	*	◊	*	◊	-	*	*	*
Blue	*	-	*	*	*	◊	*	◊	-	*	*	*
Red	*	-	*	*	*	◊	*	◊	-	*	*	*
Yellow	*	-	*	*	*	◊	*	◊	-	*	*	*
Shadow Gray*	*	-	*	-	-	-	-	-	-	*	*	*
Candy Apple Red	††	-	††	††	††	-	††	††	-	††	-	-
Custom	†	-	†	†	†	-	-	-	-	†	†	†

*Signature Series Plate-Loaded Shade in Gray only available for workhorse

STRENGTH UPHOLSTERY COLOR CHART

Color	Signature Series									Hammer Strength		
	Single Stations and Cable Motion	Benches and Racks	Plate-Loaded	Synergy980*	Pro2 SE Series	Pro2 Series	Circuit Series	Optima Series	Fit Series	MTS	Plate-Loaded and Benches and Racks	HD Elite
Black	*	*	*	*	*	*	*	*	*	*	*	*
Am. Beauty Red	*	*	*	*	*	◊	*	◊	-	*	*	*
Azure	*	*	*	*	*	◊	*	◊	-	*	*	*
Burgundy	*	*	*	*	*	◊	*	◊	-	*	*	*
Cranberry	*	*	*	*	*	◊	*	◊	-	*	*	*
Candy Apple Red	*	*	*	*	*	◊	*	◊	-	*	*	*
Chestnut	*	*	*	*	*	◊	*	◊	-	*	*	*
Concord	*	*	*	*	*	◊	*	◊	-	*	*	*
Crocus	*	*	*	*	*	◊	*	◊	-	*	*	*
Graphite	*	*	*	*	*	◊	*	◊	-	*	*	*
Dove Gray	*	*	*	*	*	◊	*	◊	-	*	*	*
Emerald	*	*	*	*	*	◊	*	◊	-	*	*	*
Grotto	*	*	*	*	*	◊	*	◊	-	*	*	*
Gun Metal	*	*	*	*	*	◊	*	◊	-	*	*	*
Hunter Green	*	*	*	*	*	◊	*	◊	-	*	*	*
Imperial Blue	*	*	*	*	*	◊	*	◊	-	*	*	*
Jade	*	*	*	*	*	◊	*	◊	-	*	*	*
Navy	*	*	*	*	*	◊	*	◊	-	*	*	*
Northwoods Green	*	*	*	*	*	◊	*	◊	-	*	*	*
Paprika	*	*	*	*	*	◊	*	◊	-	*	*	*
Plum	*	*	*	*	*	◊	*	◊	-	*	*	*
Royal Blue	*	*	*	*	*	◊	*	◊	-	*	*	*
Putty	*	*	*	*	*	◊	*	◊	-	*	*	*
Regimental Blue	*	*	*	*	*	◊	*	◊	-	*	*	*
Slate	*	*	*	*	*	◊	*	◊	-	*	*	*
Space Blue	*	*	*	*	*	◊	*	◊	-	*	*	*
Suede	*	*	*	*	*	◊	*	◊	-	*	*	*
Terra Cotta	*	*	*	*	*	◊	*	◊	-	*	*	*
Turquoise	*	*	*	*	*	◊	*	◊	-	*	*	*
Wheat	*	*	*	*	*	◊	*	◊	-	*	*	*
Custom	†	†	†	†	†	†	†	-	-	†	†	†

*Synergy980 upholstery only available for Rack and/or

Romans and Custom frame and upholstery are available for an additional charge.

Signature Series Cable Motion



Define Your Own Path

That's exactly what you will do with Cable Motion™ Technology from Life Fitness. It's multi-dimensional strength training. It's user-defined paths of motion that allow for an endless variety of exercises that build balance, stability, and power. It's infinite training choices - single stations, multi-use and multi-jungles. Turn heads during facility tours. Spark interest among loyal patrons. Boost revenues for your personal training programs. These are just a few of the ways the Cable Motion Series can help you achieve success.

Cable Motion Features

Give your exercisers the freedom to move limbs independently of one another, one at a time, both at the same time, or use different weights for each limb.

Encourage member retention by motivating your users to reach new levels of strength training with advanced exercise opportunities.

Increase your personal-training revenue with easy-to-use equipment that allows your trainers to design an unlimited number of programs.

Attract a variety of exercisers, regardless of their fitness goals or skills, with low starting resistance and easy adjustments.

Provide your users with the ideal functional training tools to help them add more strength to their everyday, real-life activities. Active older adults will improve performance in activities of daily living; - Athletes will improve on-the-field performance; Work-specific exercises will reduce on-the-job injuries

Enhance workout variety with unique swiveling handles.

Life Fitness

Signature Series

(Single Station & Cable Motion)



Reimagining Strength Training

Introduced in 2003, Signature Series has evolved and expanded, allowing facility owners and designers to create customized environments.

The series features frame and upholstery color options, and now StackWraps™ on single station and cable motion machines to perfectly blend functionality and aesthetics.



A natural feel

Created by industry pioneers, all Signature Series machines have been tested to mirror the natural movements and strength profile of an exerciser.

A comprehensive look

Signature Series uses upscale elements including curved lines, sculpted pads and premium finishes for a dynamic look across the family of products.

Expand your workout

A dependable workout, from start to finish, the Signature Series has added a Pectoral Fly/Rear Deltoid, Assisted Dip Chin, Prone Leg Curl and more-offering users a complete strength-building workout.



Life Fitness

Signature Series

(Single Station & Cable Motion)

Gallery Collection™

Try a preselected design combination, or create your own.



A customized environment

Going beyond frame and upholstery colors, StackWraps™ take our Single Station and Cable Motion machines to a new level of expression. Using technology developed for the automotive industry to withstand harsh conditions, our wraps add an eye-catching look for years to come.

Life Fitness

Signature Series

(Single Station & Cable Motion)



Reimagined for your needs

Design Options

1. Choose your StackWrap™



Rosewood Bamboo Bronze Steel Sky Stem

2. Choose your frame



Red Candy Apple Red Yellow Blue Ice Blue Black Midnight Platinum Nickel White

3. Choose your upholstery



American Beauty Red Cranberry Wheat Terra Cotta Royal Blue Imperial Blue Concord Black Slate Graphite

Visit lifefitness.com/SignatureDesign to see additional color options and try different combinations



CUSTOM COLORS

In addition to the colors shown here, we offer custom upholstery. Please contact your sales representative for more information.

Cable System

Project :

Item No. :

Chest Press

Key Features:

- User-defined motion provides multiple chest exercises to maximize training variations
- Smooth, easy gas-assisted seat adjustment.

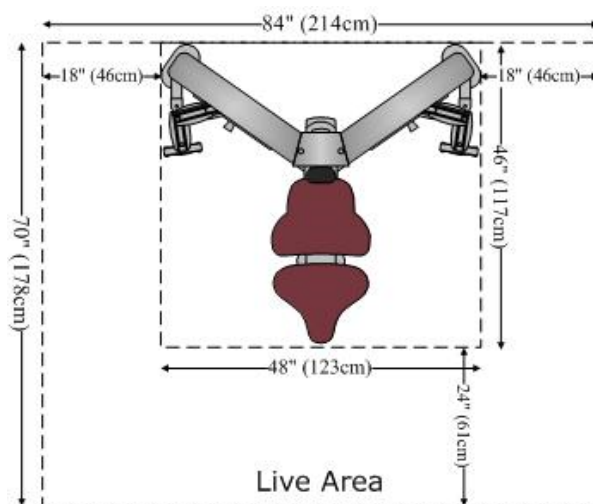
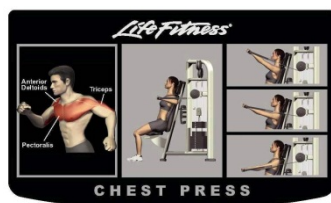

Machine Weight	680 lbs (309 kg)
Weight Stack	2 x 190 lbs (2 x 95 kg)
Dimensions (L x W x H)	49" x 46" x 64" (125 x 117 x 163) cm
Origin	Hungary
Product Code	CMCP

Cable System

Project :

Item No. :

Shoulder Press

Key Features:

- 1:2 resistance (2 x 150 lbs/2 x 75 kg) weight stacks
- Two molded handles are included
- Each handle has a dedicated weight stack for greater variety
- User-defined path of motion for shoulder exercises.
- Smooth, easy gas-assisted seat adjustment

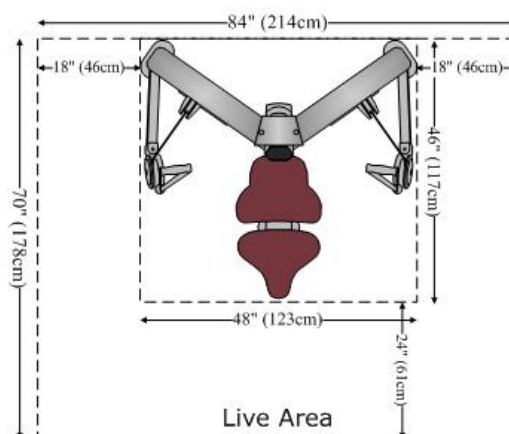

Machine Weight	600 lbs (273 kg)
Weight Stack	2 x 150 lbs (2 x 75 kg)
Dimensions (L x W x H)	46" x 46" x 64" (117 x 117 x 163) cm
Origin	Hungary
Product Code	CMSP

Cable System

Project :

Item No. :

Row

Key Features:

- 1:2 resistance (2 x 220 lbs/2 x 107 kg) weight stacks
- Two molded handles and individual row handle are included
- Each arm has a dedicated weight stack for greater variety
- Independent pulleys allow user-defined paths of motion and exercise variety.

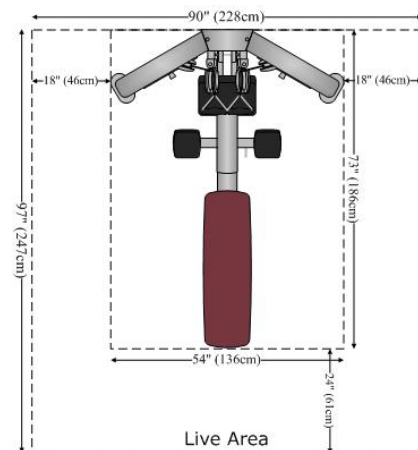

Machine Weight	770 lbs (350 kg)
Weight Stack	2 x 220 lbs (2 x 107 kg)
Dimensions (L x W x H)	73" x 54" x 67" (186 x 138 x 171) cm
Origin	Hungary
Product Code	CMRW

Cable System

Project :

Item No. :

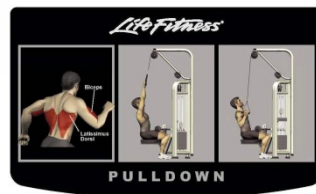

Pulldown

Key Features:

- 1:2 resistance (2 x 220 lbs/2 x 107 kg) weight stacks
- Two molded handles and individual lat pulldown bar are included
- Each arm has a dedicated weight stack for greater variety.
- Adjustable roller pads for lower body stabilization

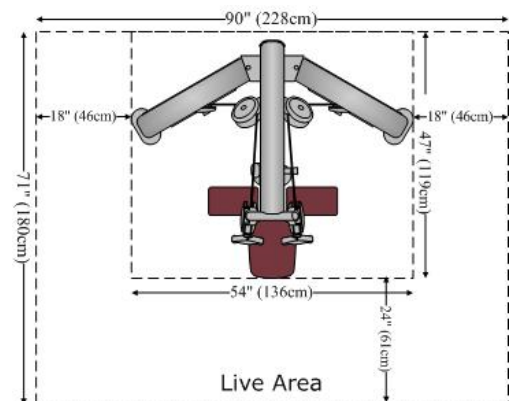

Machine Weight	810 lbs (368 kg)
Weight Stack	2 x 220 lbs (2 x 107 kg)
Dimensions (L x W x H)	54" x 45" x 95" (138 x 115 x 242) cm
Origin	Hungary
Product Code	CMPD

Cable System

Project :

Item No. :



CMS Dsual Adjustable Pulley (includes accessories)

Key Features:

- 1:4 resistance level on weight stack provides lower starting resistance ideal for less experienced users. Also allows for higher speed movements that are suitable for sport-specific training
- Dual roller mechanism or pulley housing provides a smooth and easy adjustment. 20 adjustment positions per column create a wide variety of exercises
- Standard accessory kit with 9 different handles, an instructional poster and instructional CD provide all the training tools necessary for a complete strength training program

Attachments Include: 2 Short Strap Handles, 2 Long Strap Handles, 1 Ankle Strap, 1 Leg Extension/Leg Curl Strap, 1 Triceps Rope

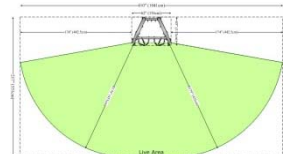

* Ceiling High Requirement 2.6m

* Vest Not Included

Machine Weight	1265 lbs (575 kg)
Weight Stack	2 x 390 lbs (2 x 195 kg)
Dimensions (L x W x H)	44" x 62" x 93" (112 x 157 x 236) cm
Origin	Hungary
Product Code	CMDAP

Cable System

Project :

Item No. : 19



CMS Dual Adjustable Pulley (includes accessories) with DAP Console

Key Features:

- 1:4 resistance level on weight stack provides lower starting resistance ideal for less experienced users. Also allows for higher speed movements that are suitable for sport-specific training
- Dual roller mechanism or pulley housing provides a smooth and easy adjustment. 20 adjustment positions per column create a wide variety of exercises
- Standard accessory kit with 9 different handles, an instructional poster and instructional CD provide all the training tools necessary for a complete strength training program

Attachments Include: **2 Short Strap Handles, 2 Long Strap Handles, 1 Ankle Strap, 1 Leg Extension/Leg Curl Strap, 1 Triceps Rope**

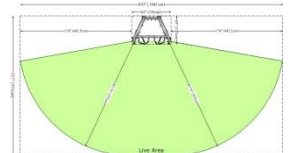

* Ceiling High Requirement 2.6m



Machine Weight	1265 lbs (575 kg)
Weight Stack	2 x 390 lbs (2 x 195 kg)
Dimensions (L x W x H)	44" x 62" x 93" (112 x 157 x 236) cm
Origin	Hungary
Product Code	CMDAP

Cable System

Project :

Item No. :



Dual Adjustable Pulley Console

Description:

This touch-screen console offers more than 60 video demonstrations. The easy-to-follow videos show exercisers how to set up the machine and perform dozens of exercises, making the Dual Adjustable Pulley even more useful for people of all fitness levels. The Console is an excellent way to provide exercise education to members without adding floor staff—anyone from trainers to front desk employees can assist an exerciser with questions.

Touch Here for Results

The innovative touch screen design makes it easy for anyone to get a challenging workout. By showing exercisers exactly how to set up the machine and perform the exercises, they can find new moves that will help them achieve better results.

Strength for Everyone

The console is compatible with all Signature Series Cable Motion Dual Adjustable Pulley machines and works to decrease intimidation of this incredibly versatile tool by offering instruction on using it and confidence that exercises - from standards to new discoveries - are being done correctly.

Two Mounting Options

The console can be mounted either directly on the machine or on a wall convenient to the machine.































Personal Trainers' Secret Asset

After viewing the large number of exercises available, people are more likely to seek the guidance of a trainer, who can keep things interesting for these new clients by accessing the more difficult moves in the "trainers only" area.

Machine Weight	11 lbs (5 kg)
Dimensions (L x W x H)	1.6" x 15" X 12" (4.1 x 38.2 x 30.5) cm
Origin	USA
Product Code	DAPCONSOLE



Signature Series Cable Motion (Dual Adjustable Pulley)

Lower Body	Core	Shoulders	Chest	Back	Variations
 SQUAT	 CRUNCH	 SHOULDER PRESS	 CHEST PRESS	 ROW	 CHEST PRESS
 LUNGE	 ROMANIAN DEAD LIFT	 LATERAL RAISE	 INCLINE PRESS	 HIGH ROW	 SHOULDER PRESS
 ABDUCTION	 ROTATION	 INTERNAL ROTATION	 DECLINE PRESS	 LOW ROW	 SQUAT
 ABDUCTION	 INCLINE ROTATION	 EXTERNAL ROTATION	 FLY	 REAR DELTOID	 WALKING LUNGE
 FLEXION	 DECLINE ROTATION				
 EXTENSION					

SAFE FITNESS FACTS :

- Read all warnings posted on the machine.
- Stay clear of weights and moving parts. Keep observers, children and pets at a safe distance. Do not allow children to play on equipment.
- Be certain weight stack selector pin is fully inserted.
- Inspect machine for worn or loose components prior to use. Pay close attention to cables and their connections. Immediately notify facility manager of any worn parts before use.
- Do not wear loose, dangling clothing or jewelry while using this equipment.
- Do not attempt to lift more weight than you can comfortably handle.
- Consult a physician prior to your exercise program. If you feel faint, dizzy or experience pain, stop and consult your physician.

Signature Series Cable Motion (Dual Adjustable Pulley)

Sample Exercise Options

FUNCTIONAL

Golf swing
Tennis swing
Lift with rotation
Baseball swing
External rotation

CHEST

Chest press
Decline chest press
Converging incline chest press
Close-grip chest press
Extended-arm pec fly
Unsupported chest press

SHOULDER / BACK

Lat pulldown
Seated row
Internal rotation
Front raise
Shoulder press
Low row
Lateral raise
Rear deltoid
One-arm fly
One-arm cable row

BICEPS

Incline biceps curl
Standing biceps curl
Seated biceps curl
Reverse biceps curl

TRICEPS

Triceps extension
One-arm triceps extension
Overhead triceps extension
Seated triceps extension
Triceps kickback

ABDOMINAL

Abdominal crunch-high pulley
Seated abdominal crunch
Kneeling abdominal crunch
Oblique twist

LOWER BODY

Standing leg extension
Standing leg curl
Hip abduction
Hip adduction
Calf raise
Lunge
Squat

Freedom of Motion

Cable Motion technology gives you control of every exercise motion. You have the freedom to perform traditional exercises, the functional moves of specific activities, or total-body movements that strengthen your core.

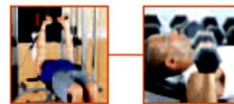

- Train for function. Perform movements that strengthen the muscles used in activities or to achieve specific goals.
- User-defined paths of motion enable virtually unlimited exercise variety-similar to lifting free weights.
- Total-body exercises target multiple muscle groups producing greater results.

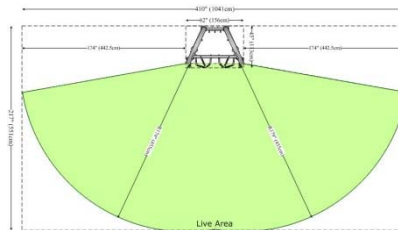

Cable System

Project :

Item No. :



Cable Column

The Life Fitness Cable Column is the perfect compliment for any strength-training program. It adds incredible training flexibility and variety, a plus for both exercisers and trainers.

Key Features:

- Dual handles create more training options
- Resistance ratio, 1:4 for each handle and 1:2 when used together, allows less experienced users to start with lower resistance
- Dual roller mechanism provides smooth and easy adjustment for the 20 different pulley positions

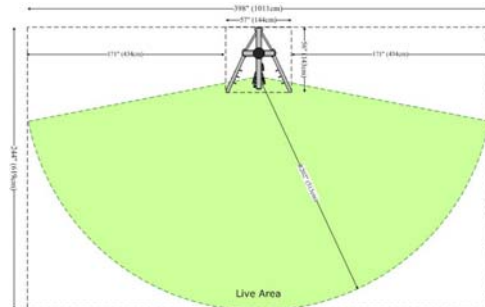

Machine Weight	685 lbs (311 kg)
Weight Stack	190 lbs (95 kg)
Dimensions (L x W x H)	56" x 57" x 92" (142 x 145 x 234) cm
Origin	Hungary
Product Code	CMCC

Cable System

Project :

Item No. :



* Ceiling High Requirement 2.7m

Adjustable Cable Crossover

The Cable Crossover utilizes select design elements and unique components of our industry-leading Signature Series and Pro2 Series strength lines to integrate nicely with all of the latest Life Fitness strength-training products.

Key Features:

- Each weight stack gives your exercisers a 1:2 resistance ratio.
- 20 easy-to-set and adjust vertical pulley positions allow your users to choose from a wide range of exercises.

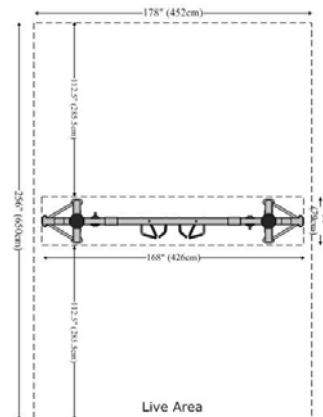

Machine Weight	980 lbs (465 kg)
Weight Stack	2 x 190 lbs (2 x 95 kg)
Dimensions (L x W x H)	28.5" x 167" x 94" (72 x 424 x 239) cm
Origin	Hungary
Product Code	CMACO

Cable System

Project :

Item No. :



Multi-Jungle (Sample 4-Stack)

With four independent stations to choose from and four weight stack towers, the MJ4 packs a lot of strength-training options in a small footprint.

Key Features:

- Up to four individuals can train on the machine simultaneously
- Available stations include: Triceps Pushdown, Lat Pulldown, Dual Pulley Pulldown, Row, Dual Pulley Row, Adjustable Pulley, Fixed Pulley Cable Crossover, Adjustable Pulley Cable Crossover
- Other configurations also available.

Stations Shown

- **Adjustable Pulley** (includes molded grip handle)
- **Dual Pulley Row** (includes fixed molded handles)
- **Triceps Pushdown** (includes triceps rope)
- **Dual Pulley Pulldown** (includes fixed molded handles)
- **Handle/Accessory Rack**



MJAP
MJRWD
MJTP
MJLPD
MJHAR

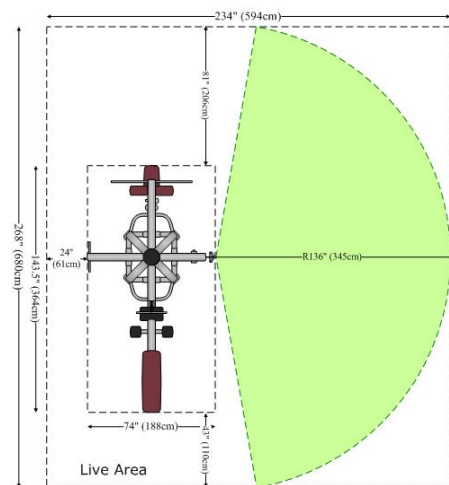

Dimensions (L x W x H)	143.5" x 74" x 94" (364 x 188 x 239) cm
Origin	Hungary
Product Code	MJ4

Cable System

Project :

Item No. :

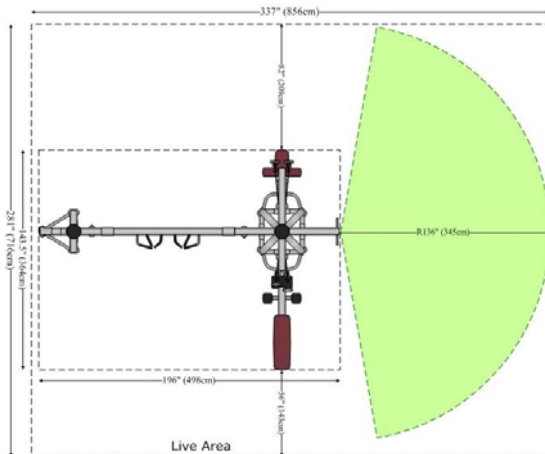

Multi-Jungle (Sample 5-Stack)

Five modular weight stacks and five independent stations.
The configurations are countless.

Key Features:

- Up to five individuals can workout simultaneously.
- Available stations include: Triceps Pushdown, Lat Pulldown, Dual Pulley Pulldown, Row, Dual Pulley Row, Adjustable Pulley, Fix Pulley Cable Crossover, Adjustable Pulley Cable Crossover
- Other configurations also available.



* Ceiling High Requirement 2.7m

Stations Shown

- **Dual Pulley Pulldown** (includes fixed molded handles)
- **Triceps Pushdown** (includes triceps rope)
- **Dual Pulley Row** (includes fixed molded handles)
- **Adjustable Crossover** (includes 2 molded grip handles)

MJLPD
MJTP
MJRWD
MJACO

Dimensions (L x W x H)	196" x 143.5" x 94" (498 x 364 x 239) cm
Origin	Hungary
Product Code	MJ5

Cable System

Project :

Item No. :

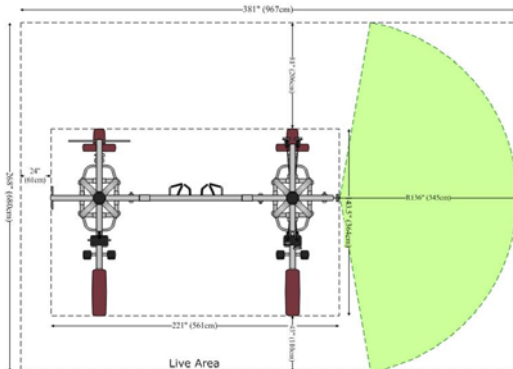

Multi-Jungle (Sample 8-Stack)

Eight modular weight stacks and eight independent stations.
The configurations are countless.

Key Features:

- Up to eight individuals can workout simultaneously.
- Available stations include: Triceps Pushdown, Lat Pulldown, Dual Pulley Pulldown, Row, Dual Pulley Row, Adjustable Pulley, Fix Pulley Cable Crossover, Adjustable Pulley Cable Crossover
- Other configurations also available.

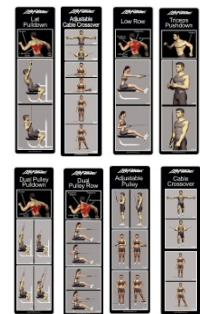

* Ceiling High Requirement 2.7m

Stations Shown

- **Lat Pulldown** (includes pulldown bar)
- **Adjustable Crossover** (includes 2 molded grip handles)
- **Low Row** (includes V-bar handle)
- **Triceps Pushdown** (includes triceps rope)
- **Dual Pulley Pulldown** (includes fixed molded handles)
- **Dual Pulley Row** (includes fixed molded handles)

- MJLP
- MJAXO
- MJRW
- MJTP
- MJLPD
- MJRWD

Dimensions (L x W x H)	221" x 143.5" x 94" (561 x 364 x 239) cm
Origin	Hungary
Product Code	MJ8

Cable System

Project :

Item No. :

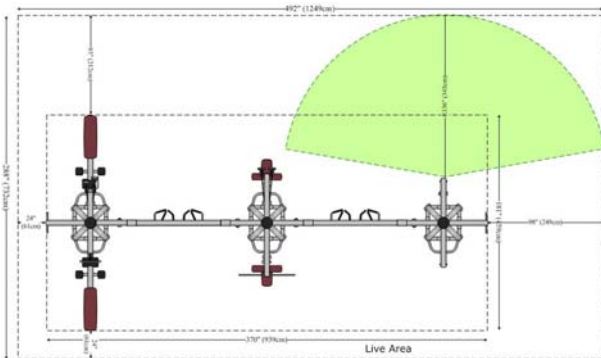

Multi-Jungle (Sample 12-Stack Straight)

Twelve modular weight stacks and twelve independent stations.
The configurations are countless.

Key Features:

- Up to twelve individuals can workout simultaneously.
- Available stations include: Triceps Pushdown, Lat Pulldown, Dual Pulley Pulldown, Row, Dual Pulley Row, Adjustable Pulley, Fix Pulley Cable Crossover, Adjustable Pulley Cable Crossover
- Other configurations also available.



* Ceiling High Requirement 2.7m

Stations Shown

- **Triceps Pushdown** (includes triceps rope)
- **Adjustable Pulley** (includes molded grip)
- **Adjustable Crossover** (includes 2 molded grip handles)
- **Lat Pulldown** (includes pulldown bar)
- **Dual Pulley Pulldown** (includes fixed molded handles)
- **Low Row** (includes V-bar handle)
- **Dual Pulley Row** (includes fixed molded handles)

- MJTP
- MJAP
- MJAXO
- MJLP
- MJLPD
- MJRW
- MJRWD



Dimensions (L x W x H)	370" x 181" x 94" (939 x 459 x 239) cm
Origin	Hungary
Product Code	MJ12S

Cable System

Project :

Item No. :

Multi-Jungle (Sample 12-Stack V-Shape)

Twelve modular weight stacks and twelve independent stations.
The configurations are countless.

Key Features:

- Up to twelve individuals can workout simultaneously.
- Available stations include: Triceps Pushdown, Lat Pulldown, Dual Pulley Pulldown, Row, Dual Pulley Row, Adjustable Pulley, Fix Pulley Cable Crossover, Adjustable Pulley Cable Crossover
- Other configurations also available.

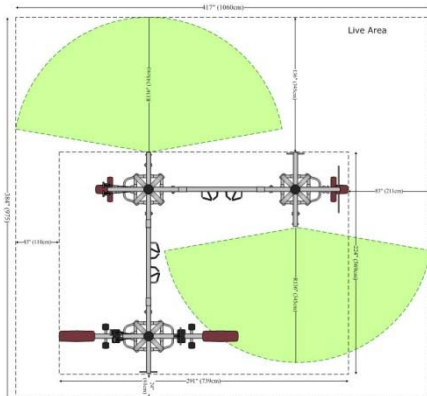

* Ceiling High Requirement 2.7m

Stations Shown

- **Triceps Pushdown** (includes triceps rope)
- **Dual Pulley Row** (includes fixed molded handles)
- **Low Row** (includes V-bar handle)
- **Adjustable Crossover** (includes 2 molded grip handles)
- **Dual Pulley Pulldown** (includes fixed molded handles)
- **Adjustable Pulley** (includes molded grip)
- **Lat Pulldown** (includes pulldown bar)

- MJTP
- MJRWD
- MJRW
- MJAXO
- MJLPD
- MJAP
- MJLP



Dimensions (L x W x H)	291" x 224" x 94" (739 x 569 x 239) cm
Origin	Hungary
Product Code	MJ12V

Cable System

Project :

Item No. :



Multi-Jungle Handle/Accessory Rack

Key Features:

- Provides convenient storage for accessories used with Cable Motion Multi-Jungles
- Mounts to the corner of any Multi-Jungle adjustable pulley station
- Includes six chrome hooks and two storage tubes to hold accessories

Machine Weight	31 lbs (14 kg)
Weight Stack	NA
Dimensions (L x W x H)	27" x 8.5" X 28" (68.5 x 21.5 x 71) cm
Origin	Hungary
Product Code	MJHAR

Free Weight Equipment

Project :

Item No. :

Hammer Strength Training Vest

Key Features:

- **Versatility.** Combining the Training Vest and Dual Adjustable Pulley gives users the ability to create resistance in all planes of movement, train dynamically or functionally and connect the body from a variety of attachment points with the color-coded rings.
- **Resistance Training.** Adding resistance to training leads to increased balance, agility, and stability as well as greater muscle strength and power. By varying ring choice and pulley height, athletes can create tension for increased resistance training.
- **Extra Assistance.** Offers the ability to take off resistance for more complex drills, while allowing for full range of motion. Securing the pulley at a high anchor point on the Training Vest provides assistance with many types of exercises.
- **Heavy-Duty, Color-Coded Rings.** Eight sets of color-coded rings allow for easy instruction and training. Each ring is made of heavy-duty stainless steel able to support up to 100 pounds.
- **Durable Construction and Size Selection.** Constructed of high-grade Neoprene and breathable mesh fabric, the Training Vest moves with your body, and is easy to clean. Sizes range from XS to XXXL (chest size 29" to 49").
- **Butterfly Clips.** Users can achieve a more custom fit with Velcro® front closure secured by two butterfly clips with adjustable straps.

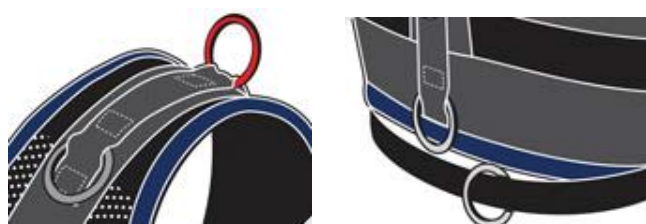

CHEST ATTACHMENT

Overhead Support
Reverse Motion

TORSO ATTACHMENT

Reverse / Diagonal
Rotational Motion

WAIST ATTACHMENT

Overhead Support
Forward / Reverse
Motion

WAIST ATTACHMENT

Vertical / Lateral
Motion

